

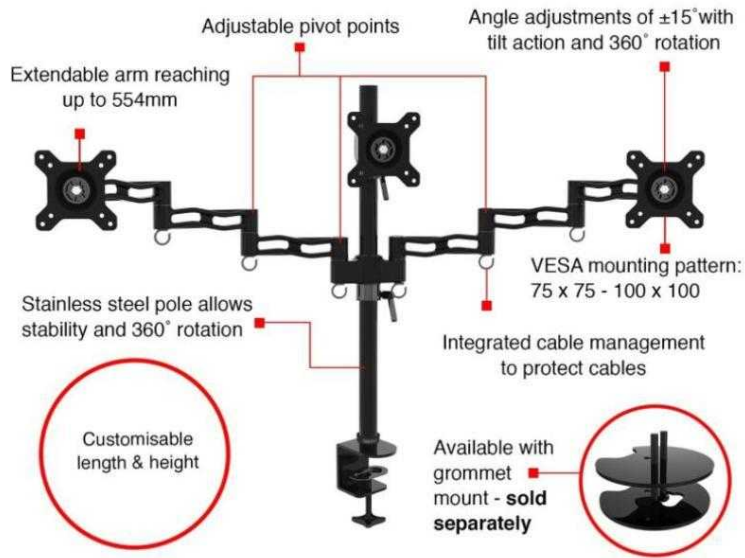





Multi monitor stand (30 GBP)

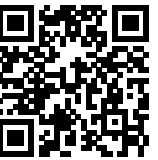
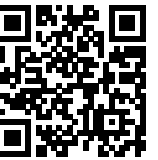
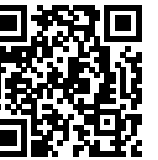

Location **East of England, Cambridgeshire**
<https://www.freeadsz.co.uk/x-248167-z>

Black Duronic DM353 Triple Three LCD LED Desk Mount Arm Monitor Stand Bracket with Tilt and Swivel (Tilt $\pm 15^\circ$ | Swivel 180° | Rotate 360°) ----- Full spec here: Link: <http://www.amazon.co.uk/dp/B00AV73QYE> ----- In great condition with the exception of a small scratch on the upright pole. This piece of kit has great flexibility and is strong and sturdy. Extra arm sections can be purchased for it also. The arms have cable clips attached for running various power and signal cables and the clamp is deep around 75-80mm so should fit most desks. ----- I also have a Kensington dock for sale if you're interested, please see here: <http://www.friday-ad.co.uk/peterborough/electronics/kensington-sd3500v-usb-3-0-universal-dock-14830739/> ;

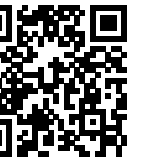
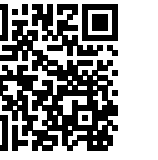
 <p>https://www.freeadsz.co.uk/x-248167-z</p> <p>Multi monitor stand</p>	 <p>https://www.freeadsz.co.uk/x-248167-z</p> <p>Multi monitor stand</p>	 <p>https://www.freeadsz.co.uk/x-248167-z</p> <p>Multi monitor stand</p>	 <p>https://www.freeadsz.co.uk/x-248167-z</p> <p>Multi monitor stand</p>	 <p>https://www.freeadsz.co.uk/x-248167-z</p> <p>Multi monitor stand</p>	 <p>https://www.freeadsz.co.uk/x-248167-z</p> <p>Multi monitor stand</p>	 <p>https://www.freeadsz.co.uk/x-248167-z</p> <p>Multi monitor stand</p>	 <p>https://www.freeadsz.co.uk/x-248167-z</p> <p>Multi monitor stand</p>	 <p>https://www.freeadsz.co.uk/x-248167-z</p> <p>Multi monitor stand</p>	 <p>https://www.freeadsz.co.uk/x-248167-z</p> <p>Multi monitor stand</p>
--	---	---	---	--	---	---	---	---	---